

2-Door Refrigerator

REF-2133



Online Warranty Registration



Please read these instructions and warranty information carefully before use and keep them handy for future reference.

USER MANUAL

Table of Contents

Warnings & Safety Precautions	03
Product Structure	08
Installation	10
Operation Instructions	12
Cleaning & Maintenance	16
Troubleshooting	17
Technical Specification	18
Warranty Terms & Conditions	35

Warnings & Safety Precautions

WARNING!

Read all instructions carefully before using this product.

- This product is for domestic indoor use only. If this product is used for any commercial, industrial, rental or other purposes, product warranty will be VOIDED.
- This product is not intended for use by children or persons with reduced physical, sensory or mental capabilities, or lack of experience and knowledge, unless they have been given supervision or instruction concerning use of this product by an adult responsible for their safety.
- Mind your children and DO NOT let children play with this product.
- Cleaning and user maintenance shall not be made by children without supervision.
- Check the voltage indicated on the rating label before using this product.
- If the supply cord is damaged, it must be replaced by the manufacturer, its service agent or similarly qualified persons in order to avoid hazards.
- Unplug this product from the power source before cleaning and maintenance. • Contact German Pool authorized service technician for repair or maintenance of this product.

In the interest of your safety and to ensure the correct use, before installing and first using this product, read this user manual carefully, including its hints and warnings. To avoid unnecessary mistakes and accidents, it is important to ensure that all people using this product are thoroughly familiar with its operation and safety features. Save these instructions and make sure that they remain with this product if it is moved or sold, so that everyone using it through its life will be properly informed on product use and safety.

For the safety of life and property keep the precautions of these user's instructions as the manufacturer is not responsible for damages caused by omission.

Children and Vulnerable People Safety

1. This product can be used by children aged from 8 years and above and persons with reduced physical, sensory or mental capabilities or lack of experience and knowledge if they have been given supervision or instruction concerning use of this product in a safe way and understand the hazards involved.
2. Children aged from 3 to 8 years are not allowed to load and unload this product.
3. Children should be supervised to ensure that they DO NOT play with this product.
4. Cleaning and user maintenance shall not be made by children unless they are aged from 8 years and above and supervised.
5. Keep all packaging well away from children. There is risk of suffocation.
6. If you are discarding this product, pull the plug out of the socket, cut the connection cable (as close to this product as you can) and remove the door to prevent playing children to suffer electric shock or to close themselves into it.

Warnings & Safety Precautions

General Safety

1. ⚠ **WARNING!** Keep ventilation openings, in this product enclosure or in the built-in structure, clear of obstruction.
2. ⚠ **WARNING!** DO NOT use mechanical devices or other means to accelerate the defrosting process, other than those recommended by the manufacturer.
3. ⚠ **WARNING!** DO NOT damage the refrigerant circuit.
4. ⚠ **WARNING!** DO NOT use other electrical appliances (such as ice cream makers) inside of refrigerating appliances, unless they are approved for this purpose by the manufacturer.
5. ⚠ **WARNING!** DO NOT touch the light bulb if it has been on for a long period of time because it could be very hot (If there is a light in the compartment).
6. ⚠ **WARNING!** When positioning this product, ensure the supply cord is not trapped or damaged.
7. ⚠ **WARNING!** DO NOT locate multiple portable socket-outlets or portable power suppliers at the rear of this product.
8. DO NOT store explosive substances such as aerosol cans with a flammable propellant in this product.
9. The refrigerant isobutane (R-600a) is contained within the refrigerant circuit of this product, a natural gas with a high level of environmental compatibility, which is nevertheless flammable.
10. During transportation and installation of this product, be certain that none of the components of the refrigerant circuit become damaged.
 - Avoid open flames and sources of ignition.
 - Thoroughly ventilate the room in which this product is situated.
11. It is dangerous to alter the specifications or modify this product in any way. Any damage to the cord may cause a short circuit, fire and/or electric shock.
12. This product is intended to be used in household and similar applications such as:
 - Staff kitchen areas in shops, offices and other working environments;
 - Farm houses and by clients in hotels, motels and other residential type environments;
 - Bed and breakfast type environments;
 - Catering and similar non-retail applications.
13. ⚠ **WARNING!** Any electrical components (plug, power cord, compressor and etc.) must be replaced by a certified service agent or qualified service personnel.
14. ⚠ **WARNING!** The light bulb supplied with this product is a “special use lamp bulb” usable only with this product. This “special use lamp” is not usable for domestic lighting (if there is a light in the compartment).
15. Power cord must not be lengthened.
16. Make sure that the power plug is not squashed or damaged by the back of this product. A squashed or damaged power plug may overheat and cause a fire.
17. Make sure that you can come to the mains plug of this product.
18. DO NOT pull the mains cable.
19. If the power plug socket is loose, DO NOT insert the power plug. There is a risk of electric shock or fire.
20. You must not operate this product without the lamp.

Warnings & Safety Precautions

21. This product is heavy. Care should be taken when moving it.
22. DO NOT remove nor touch items from the freezer compartment if your hands are damp/wet, as this could cause skin abrasions or frost/freezer burns.
23. Avoid prolonged exposure of this product to direct sunlight.

Daily Use

1. DO NOT put hot objects on the plastic parts in this product.
2. DO NOT place food products directly against the rear wall.
3. Frozen food must not be re-frozen once it has been thawed out (if there is a freezer compartment).
4. Store pre-packed frozen food in accordance with the frozen food manufacturer's instructions (if there is a freezer compartment).
5. This product's manufacturer storage recommendations should be strictly adhered to. Refer to relevant instructions.
6. DO NOT place carbonated or fizzy drinks in the freezer compartment as it creates pressure on the container, which may cause it to explode, resulting in damage to this product (if there is a freezer compartment).
7. Ice lollies can cause frost burns if consumed straight from this product (if there is a freezer compartment).
8. To avoid contamination of food, please respect the following instructions:
 - Opening the door for long periods can cause a significant increase of the temperature in the compartments of this product.
 - Clean regularly surfaces that can come in contact with food.
 - Store raw meat and fish in suitable containers in this product, so that it is not in contact with or drip onto other food.
9. If this product is left empty for long periods, switch off, defrost, clean, dry and leave the door open to prevent mould developing within this product.

Care and Cleaning

1. Before maintenance, switch off this product and disconnect the mains plug from the mains socket.
2. DO NOT clean this product with metal objects.
3. DOT NOT use sharp objects to remove frost from this product. Use a plastic scraper.

Warnings & Safety Precautions

Installation

WARNING!

For electrical connection carefully follow the instructions given in specific paragraphs.

1. Unpack this product and check if there are damages on it. DO NOT connect this product if it is damaged. Report possible damages immediately to the place you bought it. In that case retain packing.
2. It is advisable to wait at least four hours before connecting this product to allow the oil to flow back in the compressor.
3. Adequate air circulation should be around this product, lacking this leads to overheating. To achieve sufficient ventilation follow the instructions relevant to installation.
4. Wherever possible the spacers of this product should be against a wall to avoid touching or catching warm parts (compressor, condenser) to prevent possible burn.
5. this product must not be located close to radiators or cookers.
6. Make sure that the mains plug is accessible after the installation of this product

Service

1. Any electrical work required to do the servicing of this product should be carried out by a qualified electrician or competent person.
2. This product must be serviced by an authorized Service Center, and only genuine spare parts must be used.

Energy Saving

1. DO NOT put hot food in this product.
2. DO NOT pack food close together as this prevents air circulating.
3. Make sure food DO NOT touch the back of the compartment(s).
4. If electricity goes off, DO NOT open the door(s).
5. DO NOT open the door(s) frequently.
6. DO NOT keep the door(s) open for too long time.
7. DO NOT set the thermostat on exceedingly cold temperatures.
8. All accessories, such as drawers, shelves and balconies, should be kept there for lower energy consumption.

Environment Protection



This product does not contain gases which could damage the ozone layer, in either its refrigerant circuit or insulation materials. This product shall not be discarded together with the urban refuse and rubbish. The insulation foam contains flammable gases: this product shall be disposed according to the appliance regulations to obtain from your local authorities. Avoid damaging the cooling unit, especially the heat exchanger.

Warnings & Safety Precautions



The symbol on the product or on its packaging indicates that this product may not be treated as household waste. Instead it should be taken to the appropriate collection point for the recycling of electrical and electronic equipment. By ensuring this product is disposed of correctly, you will help prevent potential negative consequences for the environment and human health, which could otherwise be caused by inappropriate waste handling of this product. For more detailed information about recycling of this product, please contact your local council, your household waste disposal service or the shop where you purchased the product.

The materials used on this product marked by the symbol ♻ are recyclable.

Packaging Materials

The materials with the symbol are recyclable. Dispose the packaging in a suitable collection container to recycle it.

Disposal of This Product

1. Disconnect the mains plug from the mains socket.
2. Cut off the mains cable and discard it.

WARNING!



- During using, service and disposal of this product, please pay attention to symbol similar as left side, which is located on rear of this product (rear panel or compressor) and with yellow or orange color.
- It's risk of fire warning symbol. There are flammable materials in refrigerant pipes and compressor. Please be far away fire source during using, service and disposal.

Product Structure

Main Body

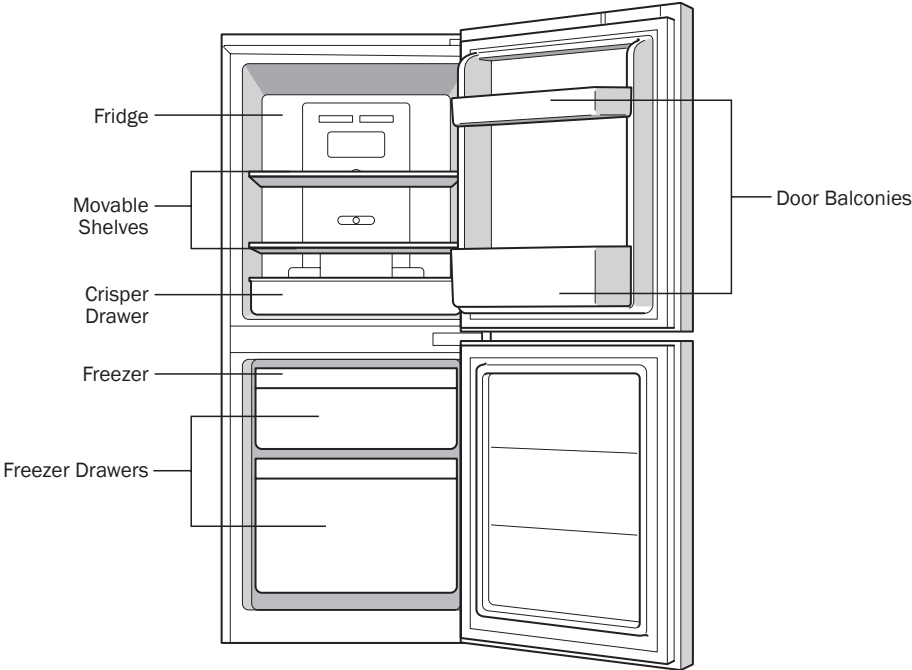

Product Structure

Accessories

Movable shelves

The walls of the fridge compartment are equipped with a series of runners so that the shelves can be positioned as desired.

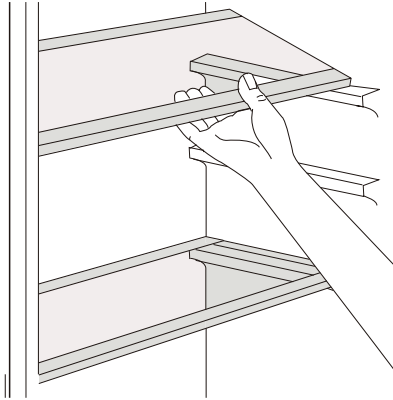

Door Balconies

Door balconies can be taken out for cleaning. To take out the balcony, carefully pull the balcony in the direction of the arrows until it comes free; after cleaning, reposition it.

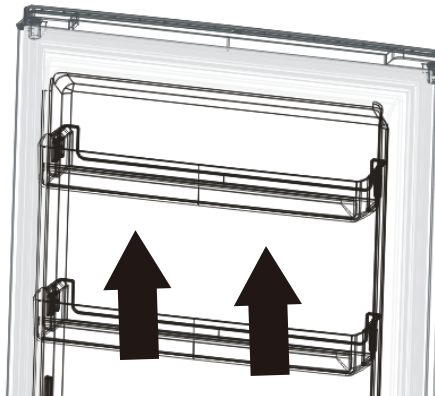

Installation

WARNING!

- This product is not intended to be used as a built-in appliance.
- It must be possible to disconnect this product from the mains power supply; the plug must therefore be easily accessible after installation.

Selecting A Suitable Location

1. Select a location without direct exposure to sunlight.
2. Select a location with enough space for the product doors to open easily.
3. Select a location with level (or nearly level) flooring. Accurate leveling is ensured by one or more adjustable feet at the base of the product.
4. Allow sufficient space to install the product on a flat surface.
5. Allow clearance to the right, left, back and top when installing. This will help reduce power consumption and keep your energy bills lower.
6. Keep at least 50mm gap at two sides and back.
7. This product should be installed well away from sources of heat such as radiators, boilers, direct sunlight etc.
8. Ensure that air can circulate freely around the back of the product.
9. To ensure best performance, if the product is positioned below an overhanging wall unit, the minimum distance between the top of the product and the wall unit must be at least 50 mm. Ideally, however, the product should not be positioned below overhanging wall units.

Electrical Connection

- Before plugging in, ensure that the voltage and frequency shown on the rating plate correspond to your domestic power supply.
- This product must be earthed. The power supply cable plug is provided with a contact for this purpose. If the domestic power supply socket is not earthed, connect this product to a separate earth in compliance with current regulations, consulting a qualified electrician.
- The manufacturer declines all responsibility if the above safety precautions are not observed.
- This product complies with the E.E.C. Directives.

Installation

Space Requirement

Keep enough space on the side of the product to ensure doors can open completely.

Keep at least 50mm gap at the two sides and the back.

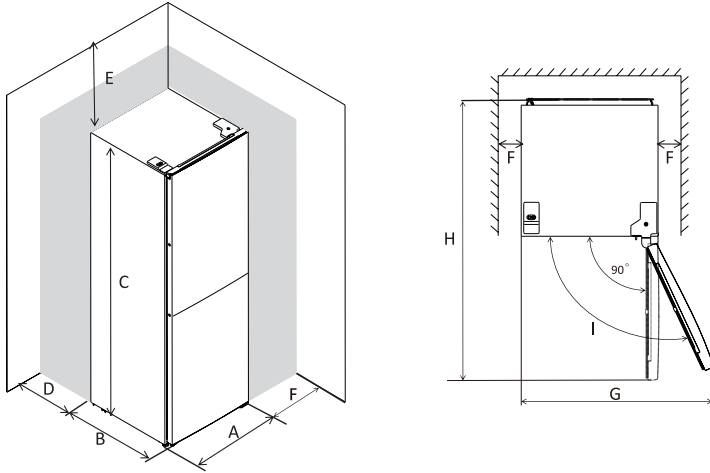

A	B	C	D	E	F	G	H	I
495mm	555mm	1140mm	Min=50mm	Min=50mm	Min=50mm	835mm	997mm	135°

Levelling the Unit

To do this, adjust the two levelling feet at the front of the unit.

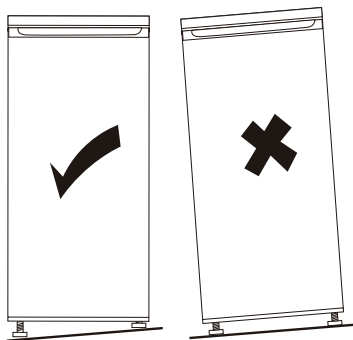

Operation Instruction

Before Use

Cleaning The Interior

Before using this product for the first time, wipe the interior and wash all internal accessories with lukewarm water and neutral detergent so as to remove the typical smell of a brand new product, then dry thoroughly.

Note:

Do not use harsh cleansers or abrasive powders, as these will damage the finish.

Setting Temperature of Refrigerator Compartment

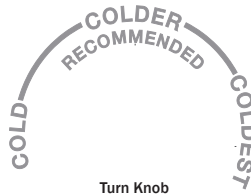

- This knob inside the refrigerator compartment is for adjusting the temperature of the refrigerator compartment.
- The internal temperature is controlled by a sensor. There are 3 settings: COLD, COLDER and COLDEST. COLD is the lowest setting and COLDEST is the highest setting. It is recommended to select COLDER setting for normal use.
- This product may not operate at the correct temperature if the ambient temperature is particularly hot or if the product door is opened frequently.



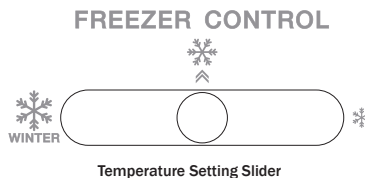

Setting Temperature of the Freezer Compartment

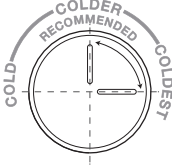

- This slider inside the refrigerator compartment is for adjusting the temperature of the freezer compartment.
- When the slider is positioned towards ❄️, the temperature in the freezer compartment will be higher; if the slider is positioned towards ❄️ WINTER, the temperature in the freezer compartment will be lower.
- It is recommended to position the slider to the middle ❄️ for normal use.
- To set the freezer compartment to the lowest temperature, adjust turn knob to COLDEST and position the slider to ❄️ WINTER.

Operation Instruction

Temperature Setting Recommendation

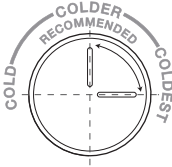
Environment Temperature	Freezer Compartment	Refrigerator Compartment
Summer (Above 38°C)	<p>FREEZER CONTROL</p> 	 <p>Set on COLDER - COLDEST</p>
Normal	<p>FREEZER CONTROL</p> 	 <p>Set on COLDER</p>
Winter (Below 16°C)	<p>FREEZER CONTROL</p> 	 <p>Set on COLDER - COLDEST</p>

- This chart is for user reference only.
- In winter or when temperature is below 16°C, user should avoid setting freezer compartment on * and refrigerator compartment on COLD.
- To save energy, use only  and COLDEST settings for special need (such as quick-freezing or ice-making), and return settings back to normal afterwards.

Operation Instruction

Daily Use

Store different foods in different compartments according to the table below:

Refrigerator Compartments	Type of Food
Door balconies	<ul style="list-style-type: none">Foods with natural preservatives, such as jams, juices, drinks, condimentsDO NOT store perishable foods
Crisper drawer (salad drawer)	<ul style="list-style-type: none">Fruits, herbs and vegetables.DO NOT store bananas, onions, potatoes, garlic in the crisper drawer
Fridge shelf - middle	Dairy products, eggs
Fridge shelf - top	Foods that do not need cooking, such as ready-to-eat foods, deli meats, leftovers
Fridge shelf - bottom	Raw food
Freezer drawer	<ul style="list-style-type: none">Foods for long-term storageRaw meat, poultry, fishFrozen vegetables, chipsIce cream, frozen fruit, frozen baked goods

Freezing Fresh Food

- The freezer drawers are suitable for freezing fresh food and storing frozen food for a long time.
- Place the fresh food to be frozen in the bottom drawer.
- The freezing process of fresh food requires 24 hours, adding new food to be frozen during this period is not recommended.

Storing Frozen Food

When first starting-up or after a period out of use, let the product run at least 2 hours on the coldest setting before putting frozen food in the freezer drawers.

Note:

In the event of accidental defrosting (eg. the power has been off for longer than 9.5 hrs), the defrosted food must be consumed quickly or cooked immediately and then re-frozen (after cooked).

Thawing

- Frozen food, prior to be used, can be thawed in the fridge compartment or at room temperature, depending on the time available for defrosting.
- Small pieces may be cooked while still frozen, directly from the freezer, but note that they will take a longer cooking time.

Operation Instruction

Hints for Freezing

- The recommended maximum quantity of new food which can be frozen in 24 hrs (Daily Freezing Capacity) is 2 kg.
- The freezing process takes 24 hours. No new unfrozen food should be added into the freezer during this period.
- Only freeze top quality, fresh and thoroughly cleaned food.
- Preparing food in small portions will enable it to be rapidly and completely frozen, and more convenient to subsequently thaw only the quantity required.
- Wrap the food in aluminum foil or polythene and make sure the packages are airtight.
- DO NOT allow fresh or unfrozen food to touch food which is already frozen, to prevent a rise in temperature of the latter.
- Lean foods store better and longer than fatty ones; salt reduces the storage life of food.
- Water ices, if consumed immediately after removal from the freezer compartment, can possibly cause the skin to be freeze burnt.
- It is recommended to mark the freezing date on each individual pack to enable you to keep tab of the storage time.
- Make sure frozen food is transferred from the retail store to the freezer in the shortest possible time.
- DO NOT open the refrigerator doors frequently or leave them open longer than absolutely necessary.
- Once defrosted, food deteriorates rapidly and cannot be refrozen.
- DO NOT exceed the storage period indicated by the food manufacturer.

Hints for Refrigeration

- DO NOT store warm food or evaporating liquids in the refrigerator.
- Cooked foods, cold dishes, etc. should be covered and may be placed on any shelf.
- For food safety and hygiene purposes, food stored in the fridge compartment should be consumed within one or two days.
- Raw food should be wrapped in polythene bag and placed on the lowest shelf just above the crisper drawer.
- Fruit and vegetables should be thoroughly cleaned and placed in the crisper drawer.
- Butter and cheese should be placed in special airtight containers or wrapped in aluminum foil or polythene bags to exclude as much air as possible.
- For energy efficiency, all drawers and shelves must be in their right place in the fridge.

Cleaning and Maintenance

WARNING!

- Before cleaning and maintenance, disconnect product from the power source by shutting off the circuit breaker or fuse box, and remove the plug from the mains, to avoid danger of electrical shock!
- DO NOT clean this product with a steam cleaner. Moisture could accumulate in electrical components, danger of electrical shock! Hot vapors can lead to the damage of plastic parts.
- Ethereal oils and organic solvents can attack plastic parts, e.g. lemon juice or the juice from orange peel, butyric acid, cleanser that contain acetic acid.
- This product must be dry before it is placed back into service.

For hygienic reasons the product's interior, including accessories, should be cleaned regularly.

1. DO NOT allow ethereal oils, organic solvents or cleansers that contain acetic acid to come into contact with this product's parts.
2. DO NOT use any abrasive cleaners.
3. Remove the food from the freezer. Store them in a cool place, well covered.
4. Switch off the product and remove the plug from the mains.
5. Clean the product and the interior accessories with cloth and lukewarm water.
6. After cleaning, dry off with a dry cloth
7. After everything is dry, place the product back into service.

Replacing The Lamp

The internal light is a LED type. To replace the lamp, please contact German Pool Customer Service & Repair Centre.

Troubleshooting

⚠ WARNING!

- Before troubleshooting, disconnect the power supply.
- Only qualified electricians or authorized technicians can carry out troubleshooting not mentioned in this manual.

Note:

Compressor and refrigerant circulation may emit sound during use. This is a normal phenomenon.

Problem	Possible Cause	Solution
Product does not work	Temperature regulation knob is set to COLDEST	Set the knob to a lower setting
	Mains plug is not plugged in or is loose	Insert mains plug properly
	Fuse has blown or is defective	Check fuse, replace if necessary
	Socket is defective	Socket must be replaced by qualified electrician only
Product freezes or cools too much	Temperature is set too cold or the product is running on COLDEST	Set the knob to a lower setting temporarily
The food is not frozen enough	Temperature is not properly adjusted	Please refer to Temperature Setting section
	Door was open for an extended period	Open the door only as long as necessary
	A large quantity of warm food has been placed in the refrigerator within the last 24 hours	Set the knob to a colder setting temporarily
	The refrigerator is near a heat source	Please refer to the Installation Instructions section
Heavy buildup of frost on the door seal	Door seal is not air tight	Carefully warm the leaking sections of the door seal with a hair dryer (on a cool setting). At the same time shape the warmed door seal by hand such that it sits correctly
Unusual noises	Refrigerator is not level	Re-adjust the feet
	Refrigerator is touching the wall or other objects	Move the refrigerator slightly so that it does not touch other objects
	A component (eg. a pipe on the rear of the refrigerator) is touching another part of the product or the wall	If necessary, carefully bend the component out of the way
Side panels are hot	It's normal. Heat exchange parts are in the side panels	Wear gloves to touch sides if needed

⚠ WARNING!

If problem persists, contact German Pool Customer Service & Repair Centre. DO NOT disassemble product by yourself.

Technical Specification

Model	REF-2133
Voltage / Frequency	220-240 V / 50 Hz
Rater Power (Max)	110 W
Dimensions	(H) 1140 (W) 495 (D) 555 mm
Total Capacity	133 L
Net Weight	33 kg
Max Daily Freezing Capacity (24 hrs)	2 kg
Preservation Time Without Electricity	9.5 hrs

- Specification is subject to change without prior notice.
- If there is any inconsistency or ambiguity between the English version and the Chinese version, the English version shall prevail.
- Refer to www.germanpool.com for the most update version of the user manual.

目錄

警告及注意事項 20

產品結構 24

安裝說明 26

使用說明 28

清潔與保養 32

故障檢修 33

技術規格 34

保用條款 35

警告及注意事項

⚠ 警告！

使用本產品前，請仔細閱讀所有說明。

- 本產品只限家居室內日常使用，如產品作任何商業、工業、出租或其他用途，保用證即告失效。
- 請勿讓兒童或身體有殘障、精神不健全及對本產品缺乏經驗或知識的人士單獨使用本產品；如需使用，必須要在負責任的成年人監管下方可使用。
- 應照顧好兒童，確保他們不會玩耍本產品。
- 無成年人監管下，勿讓兒童清潔及維護本產品。
- 使用前，請先檢查所有電壓是否與本產品標籤上的電壓相符。
- 如果電源線損壞，為免發生意外，電源線必須由廠方、廠方指定的維修中心或同等合格的技術人員進行更換。
- 清潔或檢查本產品前，必須先關機及拔掉插頭。
- 請聯繫德國寶授權的技術人員進行維修或保養本產品。

為了您的安全並確保正確使用，在安裝和首次使用本產品之前，必須仔細閱讀本說明書，包括當中的提示和警告。為避免不必要的錯誤和事故，確保所有使用本產品的人都完全熟悉其操作和安全特性。必須妥善保管本說明書，並確保在移動或出售本產品時將其保留在本產品中，以便所有使用者都能正確了解本產品的使用和安全性。

為了生命和財產的安全，請遵守本說明書中的注意事項，本公司不會對因疏忽或錯誤使用所造成的損失負責。

兒童和弱勢群體安全

1. 本產品可供8歲或以上的兒童以及身體、感官或精神能力受損或缺乏經驗和知識的人使用，前提是他們已獲得監督或有關以安全方式使用本產品的指導，並且了解所涉及的危險。
2. 嚴禁3至8歲的兒童使用本產品。
3. 應監督兒童，以確保他們不會玩耍本產品。
4. 8歲或以上的兒童必須在有監督的情況下才能進行清潔和維護。
5. 必須讓兒童遠離所有包裝，有窒息의危險。
6. 如要棄置本產品，請將插頭從插座中拔出，剪斷連接線（盡可能貼近產品）並取下門，以防止兒童玩耍時觸電或將自己關在門內。

一般安全說明

1. ⚠ 警告！保持本產品外殼或內置結構中的通風口暢通無阻。
2. ⚠ 警告！嚴禁使用製造商推薦以外的機械裝置或其他方式加速除霜過程。
3. ⚠ 警告！嚴禁損壞製冷劑迴路。
4. ⚠ 警告！嚴禁在本產品內使用其他電器（如雪糕機），除非製造商允許使用。
5. ⚠ 警告！如燈泡長時間亮著，嚴禁觸摸，因為它可能非常熱（如產品內有燈）。
6. ⚠ 警告！放置本產品時，必須確保電源線沒有被夾住或損壞。
7. ⚠ 警告！嚴禁在本產品後部放置多個便攜式插座或便攜式電源。

警告及注意事項

8. 嚴禁在本產品中存放易爆物品，例如帶有易燃推進劑的噴霧罐。
9. 本產品的製冷劑迴路中含有製冷劑異丁烷 (R-600a)，這是一種具高度環境兼容性的天然氣，但仍要注意它是易燃的。
10. 在本產品的運輸和安裝過程中，必須確保製冷劑迴路的任何部件都沒有損壞。
 - 避免明火和火源。
 - 本產品所在的房間必須充分通風。
11. 以任何方式更改規格或修改本產品都是危險的。如電源線損壞可能導致短路、火災及/或觸電。
12. 本產品旨在用於家庭和類似應用，例如：
 - 商店、辦公室和其他工作環境中的員工廚房區；
 - 農舍和酒店、汽車旅館和其他住宅類型環境；
 - 民宿型環境；
 - 餐飲和類似的非零售應用。
13. ⚠ **警告！**任何電氣組件（插頭、電源線、壓縮機等）必須由認可的服務代理或合資格的技術人員更換。
14. ⚠ **警告！**本產品隨附的燈泡是「特殊用途燈」，僅可與本產品一起使用。此「特殊用途燈」不能用於家庭照明（如產品內有燈）。
15. 嚴禁加長電源線。
16. 必須確保電源插頭沒有被本產品背面壓扁或損壞。壓扁或損壞的電源插頭可能會過熱並引起火災。
17. 必須確保安裝後使用者仍可接觸到本產品所使用的電源插頭。
18. 嚴禁拉扯電源線。
19. 如電源插座鬆動，嚴禁插入電源插頭，有觸電或火災危險。
20. 嚴禁照明燈損壞的情況下操作本產品。
21. 本產品有一定重量，移動時必須小心。
22. 嚴禁用濕手從冷凍室取出或觸摸物品，因為這可能導致皮膚擦傷、凍傷或冷凍灼傷。
23. 避免本產品長時間暴露在陽光直射下。

日常使用

1. 嚴禁放置熱的物品在本產品內的塑料部件上。
2. 嚴禁將食品直接貼靠在冷藏室或冷凍室背壁。
3. 冷凍食品解凍後不可重新冷凍（如果產品設有冷凍室）。
4. 必須按照冷凍食品製造商的說明存放預先包裝好的冷凍食品（如果產品設有冷凍室）。
5. 必須嚴格遵守製造商的存儲建議，請參閱相關說明。
6. 嚴禁將碳酸飲品放入冷凍室，因為它會對容器產生壓力，可能會導致爆炸，從而損壞本產品（如果產品設有冷凍室）。
7. 如即時食用從本產品中取出的冰棒有可能導致凍傷（如果產品設有冷凍室）。
8. 為避免污染食物，請遵守以下說明：
 - 長時間打開雪櫃門會導致本產品內的溫度顯著升高。
 - 必須定期清潔可能與食物接觸的表面。
 - 必須將生肉和魚存放在合適容器再放入本產品，以免接觸其他食物或滴落到其他食物上。

警告及注意事項

9. 如長時間不使用本產品，請切斷電源、除霜、清潔、乾燥並讓門保持打開狀態以防本產品內部發霉。

清潔和保養

1. 清潔和保養前，必須切斷本產品電源並從電源插座上拔除電源插頭。
2. 嚴禁使用金屬物品清潔本產品。
3. 嚴禁使用鋒利的物品去除本產品上的霜，建議使用塑料刮刀。

安裝

⚠ 警告！

關於電氣連接，請仔細遵以下段落的說明。

1. 打開本產品包裝，檢查是否有損壞。如本產品已損壞，嚴禁連接。立即聯絡你的零售商報告損壞，在此情況下必須保留包裝。
2. 建議在安裝後至少等待4小時後才連接本產品的電源，讓機油流回壓縮機中。
3. 本產品周圍必須有足夠的空氣流通，否則會導致過熱。要確保足夠的通風，請遵循與安裝相關的說明。
4. 產品的墊片應盡可能靠牆，以避免接觸或夾住發熱的部件（壓縮機、冷凝器），以防止可能的燒傷。
5. 嚴禁讓本產品靠近散熱器或炊具。
6. 確保安裝本產品後電源插頭可以觸及。

服務

1. 維修本產品時所涉及的任何電氣工作必須由合格的電工或合資格人員進行。
2. 本產品必須由授權的服務中心進行維修，並且只能使用正品備件。

節能

1. 嚴禁將熱食放入本產品內。
2. 嚴禁將食物緊密擺放在一起，避免阻礙空氣流通。
3. 確保食物不會接觸到隔間的背壁。
4. 停電期間，請勿打開雪櫃門。
5. 嚴禁頻繁開門。
6. 嚴禁讓門開太久。
7. 嚴禁將溫度設置過冷。
8. 所有配件包括抽屜、層架等應妥善安裝在本產品內以降低能耗。

警告及注意事項

環境保護



本產品的製冷劑迴路及絕緣材料中均不含會破壞臭氧層的氣體。本產品不得與城市垃圾、一般垃圾一起丟棄。絕緣泡沫中含有易燃氣體：本產品應根據政府的電器回收規定進行處理。避免損壞冷卻裝置，尤其是熱交換器。

本產品上使用標有 ♻ 符號的材料是可回收的。



本產品及其包裝上的符號表示本產品不得作為家居垃圾處理。相反，它應該被帶到適當的電器和電子設備收集點回收。通過正確處置本產品，您將有助於防止對環境和人類健康造成的潛在負面影響，避免因不當處理本產品而導致任何負面影響。有關本產品回收的更多詳細信息，請聯繫所在地的垃圾處理服務機構或購買本產品的商店。

包裝材料

帶有符號的材料是可回收的。將包裝放入合適的收集容器中進行回收。

棄置本產品

1. 從電源插座上拔除電源插頭。
2. 切斷電源線並丟棄。

⚠ 警告！



- 在使用、維修和棄置本產品時，請注意類似於左側的符號，位於本產品（後面板或壓縮機）的背面，顏色為黃色或橙色。
- 這是火災風險警告的符號。製冷劑管道和壓縮機中有易燃物質。使用、維修和棄置時必須遠離火源。

產品結構

主機

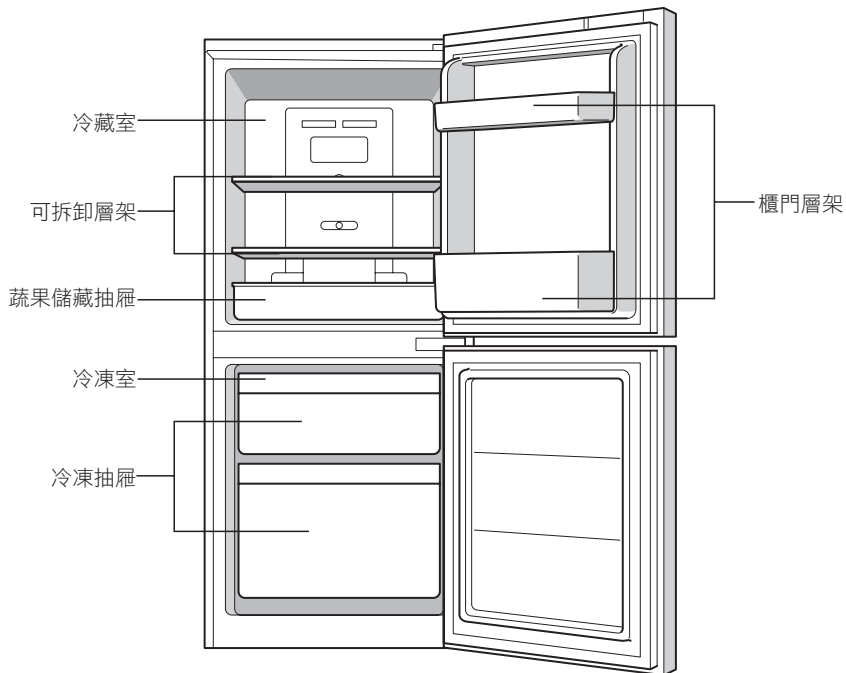

產品結構

配件

可拆卸層架

冷藏室的內壁配備了一系列滑道，用戶可以按需要調整層架。

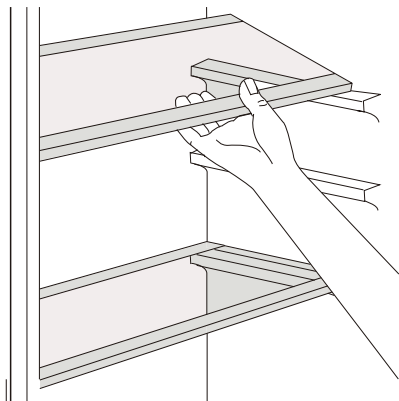

櫃門層架

櫃門層架可以拆出清洗，向上拉動櫃門層架以將其拆出，清潔後重新裝回櫃門即可。

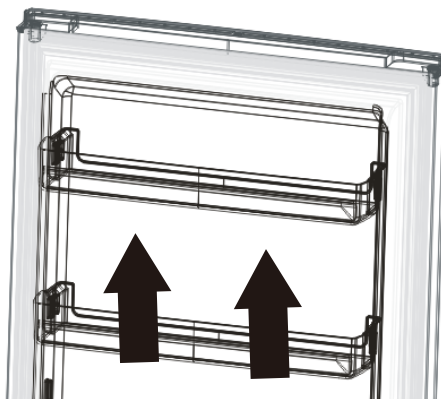

安裝說明

⚠ 警告！

- 本產品不適合用作嵌入式安裝。
- 必須確保可以斷開本產品與主電源的連接，因此，安裝後必須仍能觸及插頭。

安裝位置

1. 選擇沒有陽光直射的位置。
2. 選擇一個空間足夠大的位置，讓雪櫃門容易打開。
3. 選擇地板平整（或接近平整）的位置。可調節本產品底部支腳以確保準確調平。
4. 留出足夠的空間將本產品安裝在平坦的表面上。
5. 安裝時要預留出左右、背部和頂部的間隙。這有助減低耗電量，減少電費開支。
6. 兩側和背面至少保持50mm的間隙。
7. 本產品必須安裝在遠離熱源的地方，例如散熱器、鍋爐、陽光等。
8. 確保空氣可以在機背自由流通。
9. 為確保最佳性能，如果本產品安裝於吊櫃的下方，則本產品頂部與該懸掛物的最小距離為50毫米。然而，在理想情況下，本產品不應安裝在吊櫃下方。

電氣連接

- 插入電源插頭之前，必須確保銘牌上顯示的電壓和頻率與您的家用電源相對應。
- 本產品必須接地，電源電纜插頭設有一個觸點，如果家用電源插座未接地，請諮詢合格的電工，將本產品連接到符合現行規定的單獨接地端。
- 如果不遵守上述安全預防措施，本公司將不承擔任何責任。
- 本產品符合E. E. C. 指引。

安裝說明

安裝空間要求

- 本產品兩側必須保持足夠空間讓雪櫃門能正常打開。
- 本產品兩側和背面與牆和其他物品至少保持50mm的間隙。

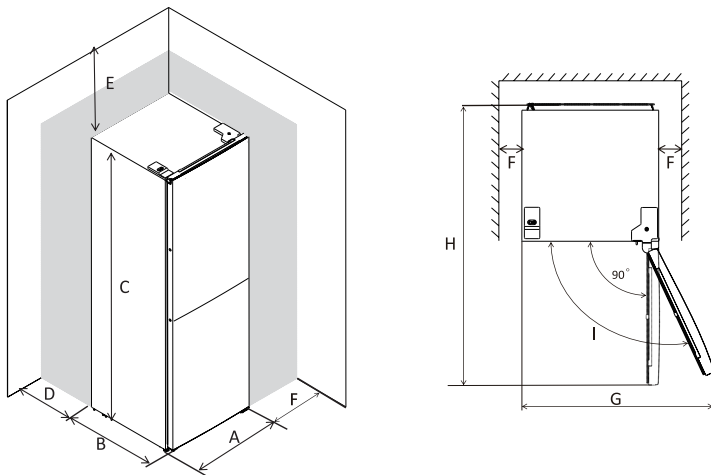

A	B	C	D	E	F	G	H	I
495mm	555mm	1140mm	Min=50mm	Min=50mm	Min=50mm	835mm	997mm	135°

水平放置本產品

- 請使用本產品前方的兩個底部支腳調平。

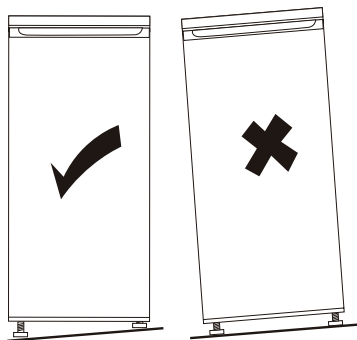

使用說明

首次使用

清潔內部

首次使用本產品前，用溫水及中性洗潔精清洗內部和所有內部配件，去除全新產品的氣味，然後徹底擦乾。

注意：

嚴禁使用強烈清潔劑或研磨粉，避免損壞飾面。

設置冷藏室溫度



- 冷藏室的旋鈕用於調節冷藏室的溫度。
- 內部溫度由傳感器控制。共有3種溫度設置，分別為「COLD」、「COLDER」和「COLDEST」，「COLD」是製冷最低的設置，「COLDEST」是製冷最高的設置。建議平常使用「COLDER」設置。
- 如擺放在特別熱的位置或經常開雪櫃門，可能導致本產品無法在正確的溫度下運行。



設置冷凍室溫度



- 冷藏室中的滑動欄用於調節冷凍室的溫度。
- 將滑塊移向❄️方向，冷凍室的溫度會較高。相反，如果將滑塊移向❄️，冷凍室的溫度會降低。
- 平常使用，建議選擇滑動欄中央的❄️設置。
- 如要將冷凍室設置到最低溫度，請將冷藏室的旋鈕調節到「COLDEST」，並將滑動欄調校至❄️位置。

使用說明

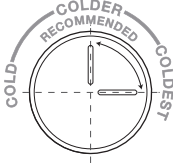
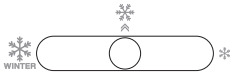
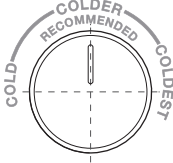
設置溫度建議

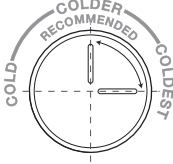
環境溫度	環境溫度	環境溫度
夏季 (38°C 或以上)	<p>FREEZER CONTROL</p> 	 <p>Set on COLDER - COLDEST</p>
正常使用	<p>FREEZER CONTROL</p> 	 <p>Set on COLDER</p>
冬季 (16°C 或以下)	<p>FREEZER CONTROL</p> 	 <p>Set on COLDER - COLDEST</p>

- 以上信息僅為用戶提供溫度設置建議。
- 冬季或氣溫低於16°C，用戶應避免設置 * 和「COLD」。
- 為節能起見，只有在有特別需要時才使用  和「COLDEST」設置（例如需要速凍或製冰時），使用後下調回「正常使用」設置。

使用說明

日常使用

用戶可根據下表將不同的食物儲存在本產品不同的位置：

儲存位置	食物種類
櫃門層架	<ul style="list-style-type: none">含天然防腐劑的食品，如果醬、果汁、飲料、調味品切勿儲存易腐爛的食物
蔬果儲藏盒（蔬果抽屜）	<ul style="list-style-type: none">水果、香草和蔬菜切勿把香蕉、洋蔥、薯仔、蒜頭放在蔬果儲藏盒內
冷藏室層架（中層）	乳製品、雞蛋
冷藏室層架（頂層）	不需要烹煮的食物，如即食食品、熟肉、剩菜等
冷藏室層架（底層）	生肉、待煮的食材
急凍抽屜	<ul style="list-style-type: none">長期儲存的食品生肉、家禽、魚急凍蔬菜、薯條雪糕、急凍水果、急凍烘焙食品

急凍新鮮食品

- 冷凍室適用於急凍新鮮食品和長期儲存急凍食品。
- 將待急凍的新鮮食物放入底部抽屜。
- 急凍過程需時24小時，在此期間建議不要添加其他需要冷凍的食物。

儲存急凍食品

首次啟動或停用本產品一段時間後，先讓產品於最高製冷設置運行至少2小時，才將急凍食品放入冷凍室。

注意：

如果意外解凍（例如斷電時間超過9.5小時），解凍後的食物必須盡快食用，或立即煮熟再重新急凍。

解凍

- 急凍食品在使用前，可在冷藏室或室溫下解凍，具體取決於你有多少時間解凍。
- 小塊的食物可以直接從冷凍室中取出烹調，但請注意烹飪時間會需要較長。

使用說明

急凍食品儲存提示

- 24小時內建議可急凍的最大食物量（每日最大急凍量）為2kg。
- 急凍過程需要約24小時，在此期間不應再添加食物。
- 只急凍優質、新鮮和徹底清潔的食品。
- 將食物分成小份，有助食物迅速和完全急凍，隨後可僅解凍所需的份量。
- 用鋁箔或聚乙烯將食物包起來，並確保包裝密封。
- 避免讓新鮮、未急凍的食物接觸已經急凍的食物，從而避免令後者的溫度升高。
- 精瘦食物比脂肪食物可儲存時間更長；鹽份會使食物的儲存期縮短。
- 如從冷凍室取出冰粒立即食用，可能會導致皮膚凍傷。
- 建議在每個單獨的包裝上寫上急凍日期，以便您掌握儲存時間。
- 確保急凍食品在最短時間內從要售商轉移到冷凍室。
- 避免經常打開雪櫃門，及打開門後盡快關上。
- 一旦解凍，食物會迅速變質，請勿再次冷凍。
- 避免將食物儲存超過食品製造商列出的貯存期。

新鮮食品冷藏提示

- 請勿將熱的食物或會蒸發的液體存放在冷藏室內。
- 熟食和涼菜應先蓋好，可擺放在任何層架上。
- 為食物安全及衛生起見，冷藏食物建議最多只存放一兩天。
- 生的食物應用聚乙烯袋包好，放在蔬菜抽屜上方的最低層架上。
- 水果和蔬菜應徹底清洗，並儲存在蔬果儲藏抽屜裡。
- 牛油和芝士應儲存在特殊的密封容器中，或用鋁箔或聚乙烯袋包裹，盡可能排除多餘空氣。
- 為達至節能，所有抽屜和層架，必須安裝在正確位置。

清潔與保養

⚠ 警告！

- 清潔與保養前，必須先斷電，關掉斷路器或保險絲，並從電源插座上拔除插頭，以避免觸電危險！
- 嚴禁使用蒸汽清潔器清潔本產品，濕氣可能會積聚在電氣元件中，以避免觸電危險！而且熱蒸汽會導致塑料部件損壞。
- 乙醚油和有機溶劑會腐蝕塑料部件，例如檸檬汁、橙皮汁、丁酸、含有醋酸的清潔劑。
- 清潔完成後，必須確保所有部件完全乾燥後再行使用。

出於衛生理由，應定期清潔本產品內部，包括內部配件。

1. 嚴禁使用香精油和有機溶劑避免腐蝕塑料部件，例如含有檸檬汁、橙皮汁、丁酸、醋酸的清潔劑應避免接觸到本產品部件。
2. 嚴禁使用任何研磨性清潔劑。
3. 從冷凍室中取出食物，蓋好並存放在陰涼的地方。
4. 關閉本產品並從電源插座上拔除插頭。
5. 用布和溫水清潔本產品和內部配件。
6. 清潔後用乾布擦乾。
7. 待所有部件乾燥後，再接駁電源繼續使用。

更換燈泡

本產品內置的照明燈為LED燈，如需更換，請聯繫德國寶客戶服務和維修中心。

故障檢修

⚠ 警告！

- 排除故障前，必須先斷開電源。
- 本說明書中未包含的故障排除，必須由合資格的專業電工進行。

注意：

使用期間，壓縮機、製冷劑循環有機會發出聲音，屬於正常情況。

故障現象	可能原因	處理方法
本產品不工作	溫度設置在最冷 (COLDEST)	設置其他溫度
	電源插頭未插入或鬆動	插入電源插頭
	保險絲熔斷或損壞	檢查保險絲，必要時更換新保險絲
	插座損壞	必須由合格電工更換
產品結冰或過冷	溫度設置過低或產品設置到最冷 (COLDEST)	暫時將溫度調節至較暖的設置
食物未能完全急凍	溫度調節不當	參考使用說明修正溫度設置
	櫃門長時間打開	僅在必要時打開櫃門
	在過去24小時，於雪櫃內擺放大量熱食	暫時將溫度設置為較冷
	產品靠近熱源	參照安裝說明重新安裝
門封上結霜嚴重	門封不是密封的	用風筒（使用涼風模式）同時用手塑造加熱的門封，使其正確放置
發出異常噪音	沒有水平擺放本產品	重新調整櫃腳
	本產品接觸牆壁或其他物體	稍為移動本產品，避免與其他物體接觸
	產品組件（如後部的管道）接觸到產品的另一部分或牆壁	如有必要，小心地將該組件彎曲至不接觸機身或牆壁
側板很熱	屬於正常現象，產品的熱交換部件位於產品側面	參閱清潔及保養部分如需接觸側板，可戴上手套

⚠ 警告！

如無法排解疑難，請聯繫德國寶客戶服務及維修中心。嚴禁私自拆卸本產品。

技術規格

型號	REF-2133
電壓 / 頻率	220-240 V / 50 Hz
額定功率 (最大)	110 W
產品尺寸	(H) 1140 (W) 495 (D) 555 mm
總容量	133 L
產品淨重	33 kg
每日急凍上限容量 (24小時計)	2 kg
停電保鮮時限	9.5 hrs

- 產品規格及設計如有變更，恕不另行通知。
- 中英文版本如有出入，一概以英文版為準。
- 本產品使用說明書以www.germanpool.com網上版為最新版本。

保用條款

此保用提供德國寶產品之機件在正常使用下壹年保用(自購買日起計算)。

Warranty Terms & Conditions

Under normal operations, the product will guarantee a 1-year warranty provided by German Pool (effective from the date of purchase).

* 貴戶須在購機十天內，以下列其中一種方式向本公司登記資料，保用手續方正式生效：

- 1) 填妥德國寶VIP手機應用程式保用登記表(掃描右方二維碼)
- 2) 填妥本公司網頁保用登記表
www.germanpool.com/warranty
- 3) 填妥保用卡郵寄至本公司。



* This warranty is not valid until customer registration information is received by our Service Centre within 10 days of purchase via one of the following means:

- 1) Visit our VIP App and register online:
(Scan the QR Code on the left)
- 2) Visit our website and register online:
www.germanpool.com/warranty
- 3) Complete the attached Warranty Card and mail it back to our Customer Service Centre.



另請填妥以下表格並與正本發票一併保存，以便維修時核對資料。用戶提供之所有資料必須正確無誤，否則免費保用將會無效。 Please fill out the form below. This information and the original purchase invoice will be required for any repairs. Warranty will be invalidated if information provided is found to be inaccurate.

型號 Model No. : REF-2133

機身號碼 Serial No. : _____ 發票號碼 Invoice No. : _____

購買商號 Purchased From : _____ 購買日期 Purchase Date : _____

1. 未能出示購買發票正本者，將不獲免費維修服務。
2. 用戶應依照說明書的指示操作。本保用並不包括：
 - 上門安裝、檢驗、維修或更換零件之人工以及一切運輸費用；
 - 因天然與人為意外造成的損壞(包括運輸及其他)；
 - 電源接合不當、不依說明書而錯誤或疏忽使用本機所引致之損壞。
3. 於下列情況下，用戶之保用資格將被取消：
 - 購買發票有任何非認可之刪改；
 - 產品被用作商業或工業用途；
 - 產品經非認可之技術人員改裝或加裝任何配件；
 - 機身編號被擅自塗改、破壞或刪除。
4. 總代理有權選擇維修或更換配件或其損壞部份。
5. 產品一經被轉讓，其保用即被視作無效。

1. Customer who fails to present original purchase invoice will not be eligible for free warranty service.
2. Customer should always follow the operating instructions. This warranty does not apply to:
 - labour costs for on-site installation, check-up, repair, replacement of parts and other transportation costs;
 - damages caused by accidents of any kind (including material transfer and others);
 - operating failures resulting from applying incorrect voltage, improper usage, and unauthorized installations or repairs.
3. This warranty is invalid if:
 - the purchase invoice is modified by an unauthorized party;
 - the product is used for any commercial or industrial purposes;
 - the product is repaired or modified by unauthorized personnel, or unauthorized parts are installed;
 - the serial number is modified, damaged or removed from the product.
4. German Pool will, at its discretion, repair or replace any defective part.
5. This warranty will be void if there is any transfer of ownership from the original purchaser.

客戶服務及維修中心

香港

九龍大業街59號

三湘九龍灣貨運中心地下B室

電話：+852 2333 6249

傳真：+852 2356 9798

電郵：repairs@germanpool.com

澳門

澳門青洲大馬路(青洲新路)

515號美居廣場第二期1樓A座

電話：+853 2875 2699

傳真：+853 2875 2661

Customer Service & Repair Centre

Hong Kong

Unit B, G/F, Sunshine Kowloon Bay

Cargo Centre, 59 Tai Yip Street, Kowloon

Kowloon, Hong Kong

Tel : +852 2333 6249

Fax : +852 2356 9798

Email : repairs@germanpool.com

Macau

A, 1 Andar, Mei Kui Kuong Cheong Fase 2,

No.515 Avenida Do Conselheiro Borja

Macau

Tel : +853 2875 2699

Fax : +853 2875 2661

此保用只適用於香港及澳門

This warranty is valid only in Hong Kong and Macau

German Pool (Hong Kong) Limited

Hong Kong

Room 113, Newport Centre Phase II, 116 Ma Tau
Kok Road, Tokwawan, Kowloon, Hong Kong.
Tel: +852 2773 2888
Fax: +852 2765 8215

China

8th, Xinxiang Road, Wusha Industrial Park,
Daliang, Shunde, Foshan, Guangdong
Tel: +86 757 2219 6888
Fax: +86 757 2219 6809

Macau

A, 1 Andar, Mei Kui Kuong Cheong Fase 2,
No.515 Avenida Do Conselheiro Borja, Macau
Tel: +853 2875 2699
Fax: +853 2875 2661



香港《S MARK》
安全認證



中國郵政/家電行業
十大影響力品牌



CEO非凡品牌大賞



香港優質商標



香港工商業獎



2007
最具潛質
創星品牌企業獎



香港中小企業
最佳拍檔大獎



香港消費者推祟品牌



香港《心嚮》
優質服務證書



香港名牌十年成就獎
HONG KONG TOP BRAND TEN YEAR
ACHIEVEMENT AWARD

© All rights reserved. Copying, reproducing or using the contents of this manual is not allowed without prior authorization from German Pool, violators will be prosecuted.